

UNCONTROLLED DOCUMENT

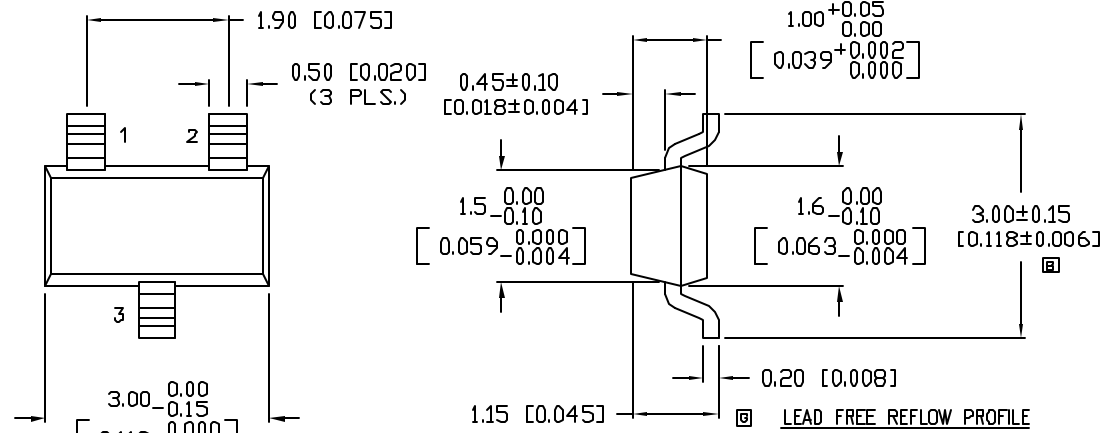

TOP VIEW POLARITY

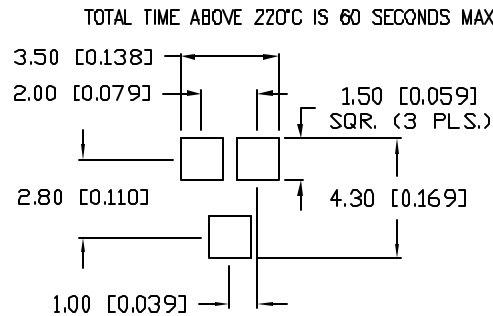
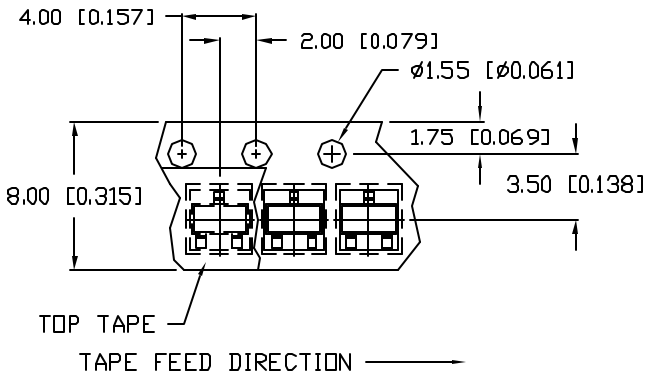
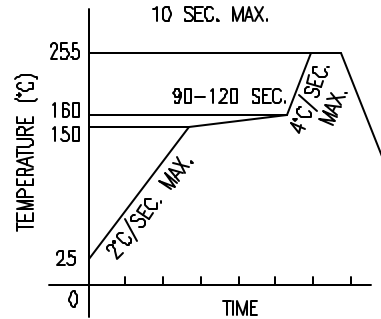
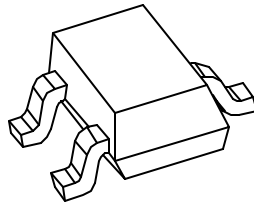
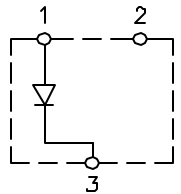

TOTAL TIME ABOVE 220°C IS 60 SECONDS MAX.

PART NUMBER		REV.
SSL-LX15GC-RP-TR		G
REV.	E.C.N. NUMBER AND REVISION COMMENTS	DATE
A	E.C.N. #10165.	5.21.96
B	E.C.N. #10412.	4.28.98
C	E.C.N. #10BRDR. & REDRAWN.	1.15.01
D	E.C.N. #10752.	5.25.01
E	E.C.N. #10877.	6.10.02
F	E.C.N. #10901.	8.22.02
G	E.C.N. #11148.	2.16.05

ELECTRO-OPTICAL CHARACTERISTICS  $T_A=25^\circ\text{C}$   $I_f=20\text{mA}$

PARAMETER	MIN	TYP	MAX	UNITS	TEST COND
PEAK WAVELENGTH		565		nm	
FORWARD VOLTAGE		2.2	2.6	V <sub>f</sub>	
REVERSE VOLTAGE	5.0			V <sub>r</sub>	I <sub>r</sub> =100μA
AXIAL INTENSITY		10		med	I <sub>f</sub> =20mA
VIEWING ANGLE		140		2x theta	
EMITTED COLOR:	GREEN				
EPOXY LENS FINISH:	WATER CLEAR				

LIMITS OF SAFE OPERATION AT 25°C

PARAMETER	MAX	UNITS
PEAK FORWARD CURRENT*	180	mA
STEADY CURRENT	25	mA
POWER DISSIPATION	100	mW
DERATE FROM 25°C	-1.2	mW/°C
OPERATING, STORAGE TEMP.	-30 TO +85	°C

\* t < 10μS

NOTES:

- 1. 3,000 PIECES PER REEL.
- 2. PIN 3 IS ORIENTED TOWARDS THE TAPE SPROCKET HOLE.
- 3. LABEL MUST BE PERMANENTLY ATTACHED TO EACH REEL.



UNCONTROLLED DOCUMENT

\*UNLESS OTHERWISE SPECIFIED TOLERANCES PER DECIMAL PRECISION ARE: X=±1 (±0.039), XX=±0.5 (±0.020), XXX=±0.25 (±0.010), XXXX=±0.127 (±0.005). LEAD SIZE=±0.05 (0.002), LEAD LENGTH=±0.75 (±0.030), MIN= +DECIMAL PRECISION -0.00, MAX.= +0.00 -DECIMAL PRECISION

REV. G	PART NUMBER SSL-LX15GC-RP-TR
SOT-23 SURFACE MOUNT 565nm GREEN LED, WATER CLEAR LENS, TAPE AND REEL.	

**CONFIDENTIAL INFORMATION**  
 THE INFORMATION CONTAINED IN THIS DOCUMENT IS THE PROPERTY OF LUMEX INC. EXCEPT AS SPECIFICALLY AUTHORIZED IN WRITING BY LUMEX INC., THE HOLDER OF THIS DOCUMENT SHALL KEEP ALL INFORMATION CONTAINED HEREIN CONFIDENTIAL AND SHALL PROTECT SAME IN WHOLE OR IN PART FROM DISCLOSURE AND DISSEMINATION TO ALL THIRD PARTIES.

**RELIABILITY NOTE**  
 OUR MANY YEARS OF EXPERIENCE DATA ACCUMULATION INDICATE THAT SOLDER HEAT IS A MAJOR CAUSE OF EARLY AND FUTURE FAILURE. PLEASE PAY ATTENTION TO YOUR SOLDERING PROCESS.

		290 E. HELEN ROAD PALATINE, IL 60067-6976 PHONE: +1.847.359.2790 US WEB: www.lumex.com TW WEB: www.lumex.com.tw
DRAWN BY: BC	CHECKED BY:	APPROVED BY:
		DATE: 2.23.95
		PAGE: 1 OF 1
		SCALE: N/A